

TROUBLESHOOTING

WARNING: BEFORE SERVICING PUMP, TURN OFF PUMP AND DRAIN WATER FROM SYSTEM!!

Failure to Prime - Motor operates, but no pump discharge

- Restricted intake or discharge line
- Air leak in intake line
- Debris in pump
- Punctured pump diaphragm (pump leaks)
- Crack in pump housing

Motor falls to turn on

- Loose wiring connection
- Pump circuit has no power
- Blown fuse
- Pressure switch failure
- Defective motor
- Open thermal protector

Pulsating Flow - Pump cycles on and off

- Restricted pump delivery. Check discharge lines, fittings and valves for clogging or undersizing.

Pump Falls to Turn Off After All Fixtures Are Closed

- Empty water tank
- Insufficient voltage to pump (low battery)
- Punctured pump diaphragm (pump leaks)
- Discharge line leak
- Defective pressure switch

Low Flow and Pressure

- Air leak at pump intake
- Accumulation of debris inside pump and plumbing
- Worn pump bearing (excessive noise)
- Punctured pump diaphragm (pump leaks)
- Defective motor

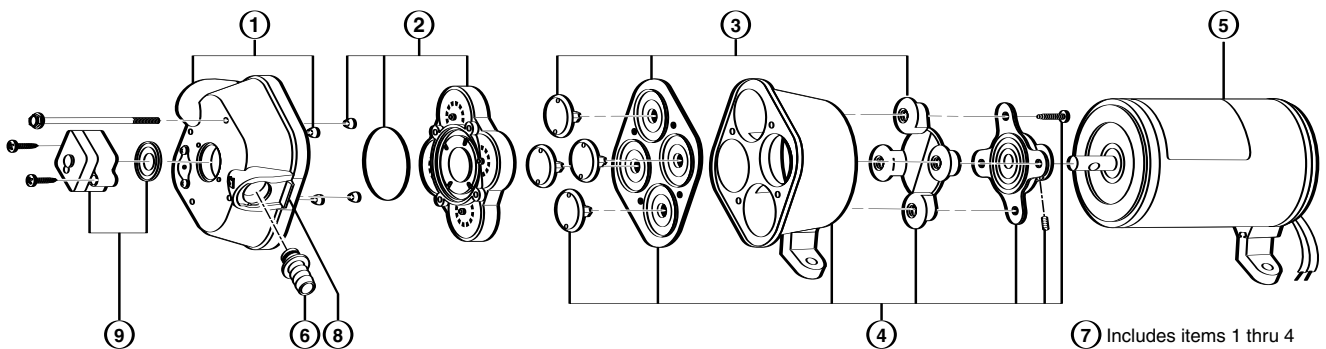

Quite often when a pump is worn or defective the one failed component has overburdened others. To avoid frequent aggravating repairs, Flojet offers service kit assemblies making repairs as quick and easy as possible.

DISASSEMBLE

Pressure Switch

1. Remove switch (9). Disconnect switch wires.

Upper Housing

2. Loosen but do not remove four pump head screws and carefully remove upper housing assembly (1)
3. Inspect check valve (2) for debris
4. Reassemble new upper housing (1)

Check Valve Assembly

- Follow step 2
3. Replace check valve (2)
 4. Reassemble upper housing (1)

Lower Housing, Diaphragm, Motor

- Follow step 2, then slide rubber foot from mounting track.
3. Rotate lower housing (4) so mounting notch opening on lower housing exposes set screw which holds bearing housing to shaft.
 4. Loosen this set screw by inserting wrench 1/8" Allen wrench into mounting notch opening. Then, slide lower housing (4) off motor shaft.

Diaphragm Cont'd

5. Loosen four cam piston screws with Phillips head screw driver and pull apart cam from inner pistons. (Pistons should always be replaced when a new diaphragm is installed.)

Motor Cont'd

5. Replace Motor

REASSEMBLE

Motor

1. Reassemble lower housing assembly (4) to motor. (Follow steps 4 to 10.)

Diaphragm

2. Lower housing is assembled with:
 - Flat side of diaphragm and outer pistons facing motor
 - Hex stem of inner pistons must be aligned into hex holes in outer pistons (4).
 - Outer pistons must be aligned with alignment slots on cam assembly making sure screw holes align in cam assembly, otherwise diaphragm will leak.
3. Tighten cam piston screws partially, center piston in diaphragm, then tighten screws securely (18 in. lbs. torque)

Lower Housing

4. Reassemble lower housing assembly (4) to motor.
5. Retighten set screw securely. Set screw head must be positioned facing motor covering seam (indentation). (Positioning of this screw is critical to avoid misalignment and subsequent diaphragm damage.)

Upper Housing, Check Valve

6. Reassemble upper housing (1)
7. Properly seat O-Ring in check valve assembly (2) and check if feeler rules and screen are in place on upper housing (1)
8. Install check valve (2) into upper housing (1) and push in.
9. Assemble on to lower housing (4), align 4 screws on to motor by rotating lower housing (4) if necessary to align feet
10. Tighten screws evenly to 30 in. lbs. torque.

Pressure Switch

1. Place switch against front of pump (9), insert screws and take care not to cross thread or strip out threads in housing.
2. Reconnect wires.

WASHDOWN PUMP SERVICE PARTS

KEY#	DESCRIPTION	MODEL#				
		4325-143	4325-343	4325-443	4325-043	4325-243
0	Service Kit*	20409-043	20409-043	20409-043	20409-043	20409-043
1	Upper Housing With Clips	20404-003	20404-003	20404-003	20404-003	20404-003
2	Check Valve Assembly	20407-030	20407-030	20407-030	20407-030	20407-030
3	Diaphragm Assembly (includes screws)	20403-040	20403-040	20403-040	20403-040	20403-040
4	Lower Housing Assembly	20419-002	20419-002	20419-002	20419-002	20419-002
5	Motors	2009-080A	2019-027A	2049-026A	—	—
	Motors CE Models	R2009-080A	R2019-027A	—	—	—
	Motor 115 Volt a.c./230 Volt a.c.	—	—	—	2029-091A	2039-087A
6	Ports - 3/4 Barb (pair)	20381-006	20381-006	20381-006	20381-006	20381-006
7	Pump Head Assembly	20406-002A	20406-002A	20406-002A	20406-002A	20406-002A
8	Side Clips (pair)	20408-000	20408-000	20408-000	20408-000	20408-000
9	Pressure Switch Assembly	02090-118	02090-118	02090-118	02090-118	02090-118

*Service Kit includes #2, #3, #8 and drive cam assembly.

ACCESSORIES

QUICK CONNECT PORT SYSTEM

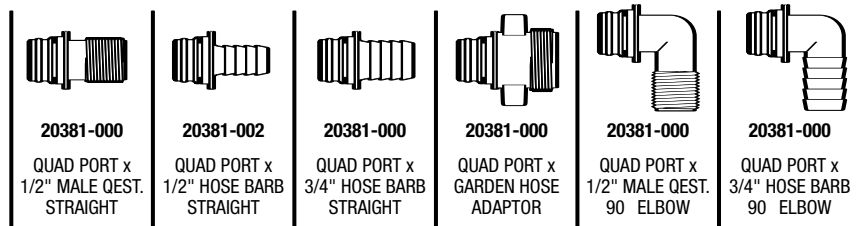

The above part numbers are packaged with 2 fittings per bag.

STRAINERS

	Pump Series	Strainer Number	Inlet	Outlet	Screen
STRAINER	4325-XXX	1740-000	3/4 Barb	3/4 Barb	40 Mesh
PRESSURE NOZZLE	4325-XXX	20446-000	3/4 GH	—	—

WARRANTY

FLOJET warrants this product to be free of defects in material and/or workmanship for a period of two years after purchase by the customer from FLOJET. During this two year warranty period, FLOJET will at its option, at no charge to the customer, repair or replace this product if found defective in material or workmanship, with a new or reconditioned product, but not to include costs of removal or installation.

This is only an overview of our limited warranty. If you would like a copy of our warranty, please call or write FLOJET.

RETURN PROCEDURE

Prior to returning any product to FLOJET, call customer service for an authorization number. This number must be written on the outside of the shipping package. Place a note inside the package with an explanation regarding the reason for return as well as the authorization number. Include your name, address and phone number.



Engineered for life

U.S.A.
Flojet
666 E. Dyer Rd.
Santa Ana, CA 92705
Phone: 714.557.4700
Fax: 714.628.8478

UNITED KINGDOM
Flojet
Bingley Road, Hoddesdon
Hertfordshire EN11 0BU
Tel: +44 (0) 1992 450145
Fax: +44 (0) 1992 467132

CANADA
Fluid Products Canada
55 Royal Road
Guelph, Ontario N1H 1T1
Tel: 519 821.1900
Fax: 519 821.2569

JAPAN
NHK Jabsco Company Ltd.
3-21-10, Shin-Yokohama
Kohoku-Ku, Yokohama, 222
Tel: 045.475.8906
Fax: 045.475.8908

GERMANY
Jabsco GmbH
Oststrasse 28
22840 Norderstedt
Tel: +49-40-53 53 73 -0
Fax: +49-40-53 53 73 -11

ITALY
Jabsco Marine Italia
Via Tommaseo, 6
20059 Vimercate, Milano
Tel: +39 039 685 2323
Fax: +39 039 666 307