

VR100 24v Fuel Transfer Pump

Features

- Faster refuelling - 105 litres/minute (28GPM)
- High head capability - 15 metres (49 feet.)
- Self priming up to 5 metres (16 feet.)
- Continuously rated*
- Thermal overload protected
- Vibration tested
- IP55 protected motor
- Full range of installation accessories
- Customised kits for OEM customers



Typical Applications

- Designed for refuelling large diesel powered vehicles [typical tank sizes 400 - 1500 litres (100 - 400 gallons)] from drums.
- This pump can be used where high flow rates, heads and superior priming performance is required.
- Suitable for mounting to the following equipment: Excavators, Cranes, Road rollers (compactors), Pavers, Agricultural machines, Generators, Helicopters.
- Suitable for diesel fuel, Kerosene, Paraffin, Hydraulic oils, Oils up to 150 centi Stokes (750 Saybolt Universal) viscosity.

Model Range

Model number	Description
VR100 - 2120	1" BSP ports, 24v DC
VR100 - 1120	32mm (1¼"), Hose ports, 24v DC
VR100 - 1122	32mm (1¼"), Hose ports, 24v DC, switch & circuit breaker
VR100 - 1123	32mm (1¼"), Hose ports, 24v DC, automatic shut off controller
Accessories	
23757 - 0010B	Check Valve kit
23759 - 0000B	Foot Valve kit
23561 - 0000G	Hose - 32mm (1¼") bore, [per metre]

Specifications

Temperature Range : -30°C to +50°C (-22°F to +122°F)

Pump Body : Cast Iron

Rotor : Sintered Iron

Vanes : Sintered Bronze

Shaft : Stainless steel

Seal : Nitrile Lip Seal

Ports : Vertical 1" BSP or 32mm hose adaptors (1¼")

Motor : 24v DC permanent magnet, thermal overload & IP55 protected

Duty : *Continuously rated up to 6 metres (20 ft.), total head of diesel fuel at 20°C (68°F)

WARNING Explosion hazard. Do not pump gasoline, solvents, thinners or other flammable liquids. To do so can cause an explosion resulting in injury or death.



Dimensions in mm (inches)

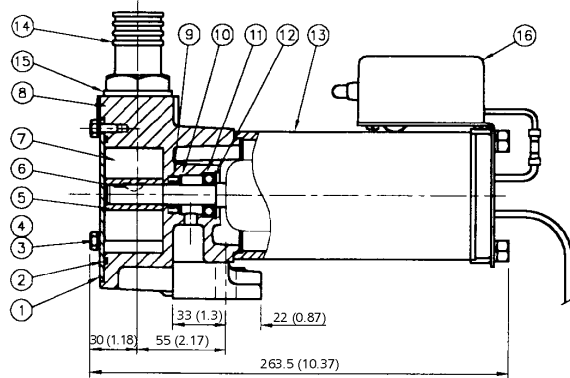
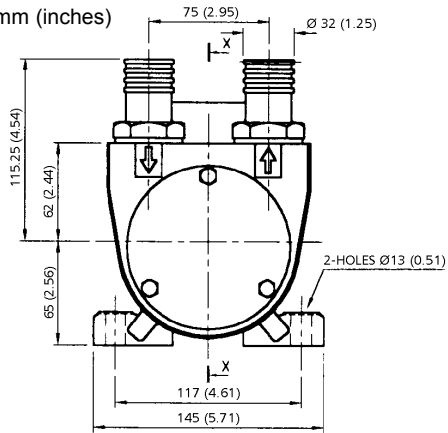

Parts List

Key	Description	Qty	Part No.
1	Endcover	1	50255-0000
2	O-ring*	1	X4020-374A
3	Screw	3	X3001-178F
4	Spring washer	3	X3081-091F
5	Rotor	1	50252-0000
6	Key*	1	SP1402-0304
7	Vane*	4	50253-0000
8	Body BSP ports	1	50254-2000
	Body NPT ports		50254-9000
9	Seal	1	SP2701-0504
10	Retaining ring	1	X5256-005
11	Bearing	1	SP2601-0457
12	Retaining ring	1	SP1701-4438
13	Motor	1	98012-9267
14	Hose adaptors	2	23633-1000
15	Sealing washer	2	SP1613-1423
16	Switch box assembly	1	23639-0240B
	Auto shut off controller		23528-0000B
Service kit contains items marked *			SK422-0000

Note

All performance information is based on diesel fuel at 20°C (68°F). On production product, this may vary by up to 10%. Maximum recommended total head of diesel fuel is 15 metres.

Safety

Do not use for pumping petrol, gasoline or products with a flash point below 37°C (99°F). Do not dry run.

Performance

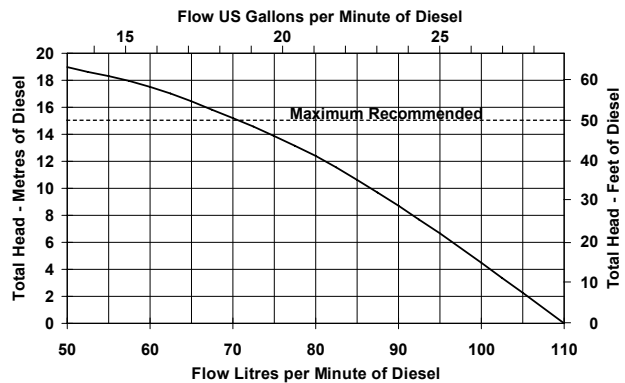

Current Draw

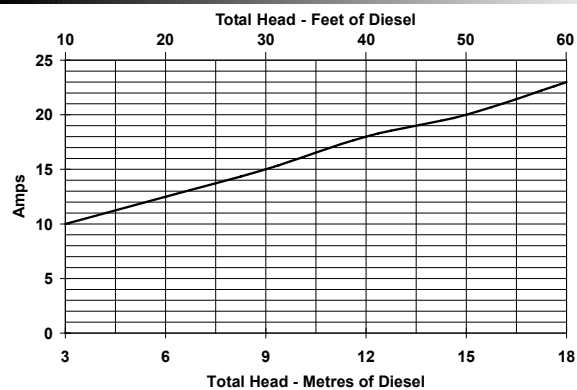

Jabsco



ITT Industries

USA

Jabsco
20 Icon
Foothill Ranch
CA 92610

Tel : +1 949 859 4945
Fax : +1 949 859 1153

UK

Jabsco
Bingley Road
Hoddesdon
Hertfordshire, EN11 0BU

Tel : +44 (0) 1992 450 145
Fax : +44 (0) 1992 467 132

GERMANY

Jabsco GmbH
Oststraße 28
22844 Norderstedt

Tel : +49 (0) 40 53 53 73 0
Fax : +49 (0) 40 53 53 73 11